

ITMX BF-LVDT:

- Calibration
- Noise level

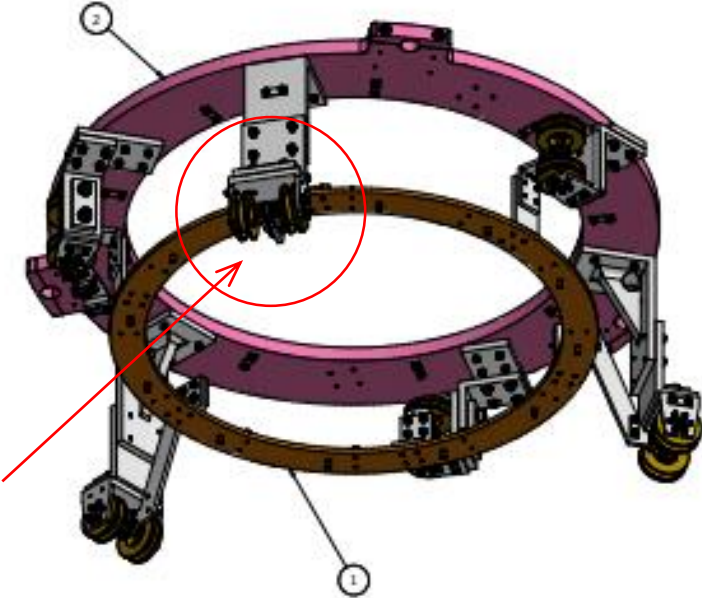

Calibration coordinate:

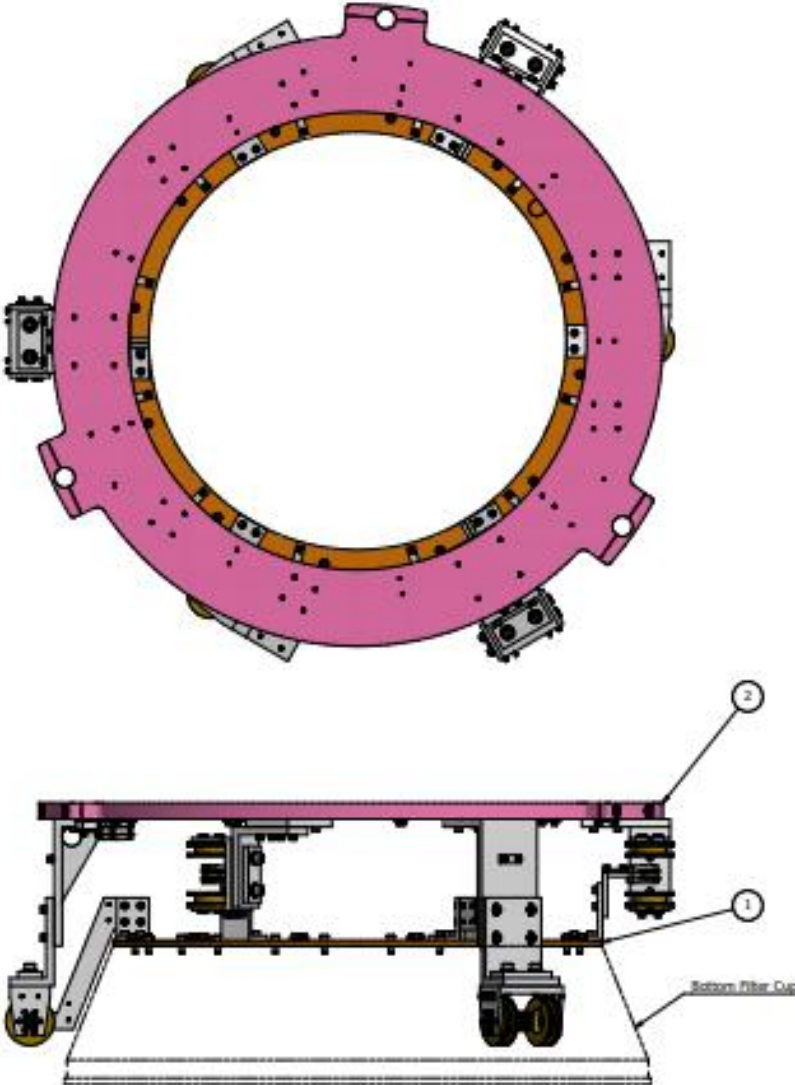
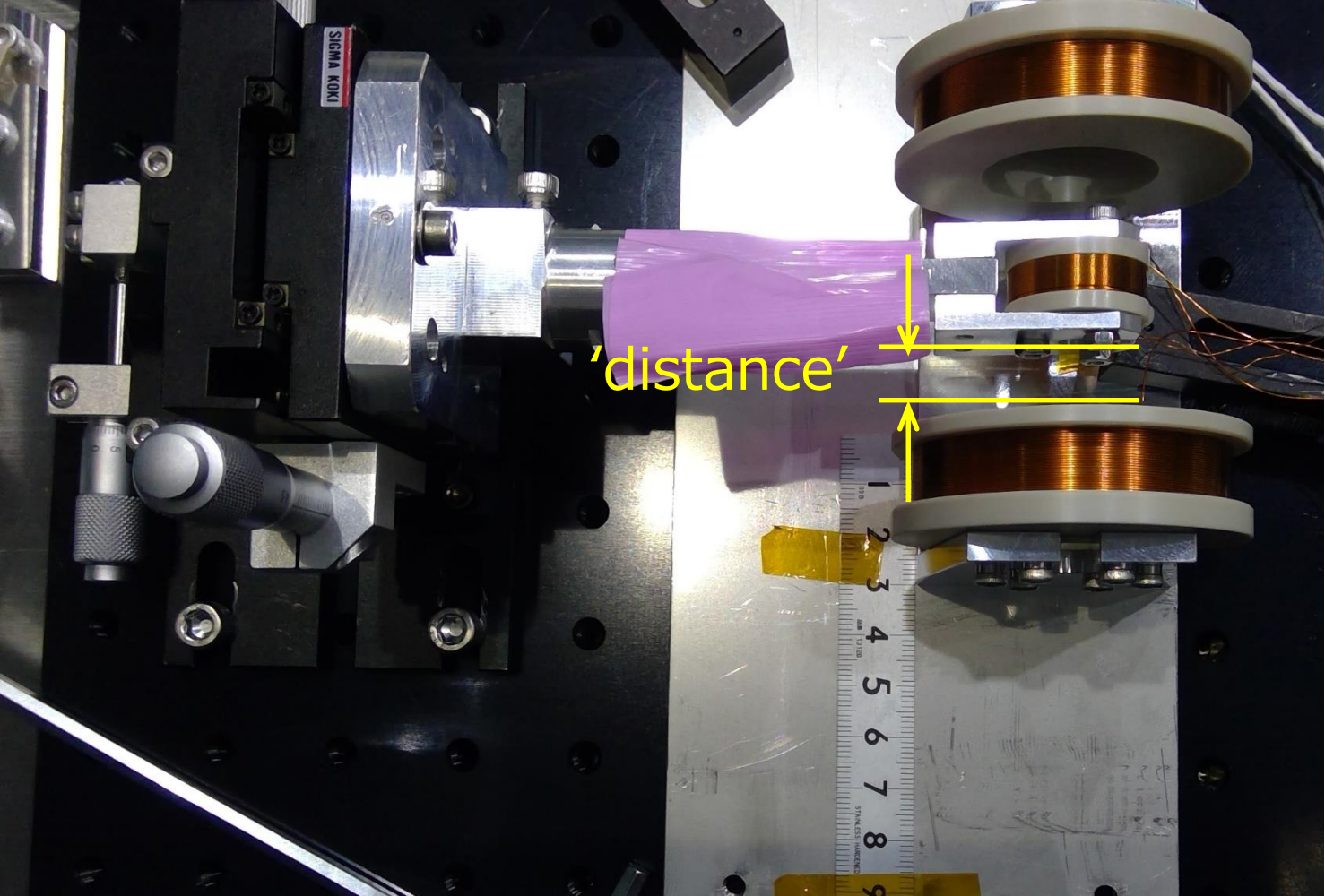

Note:

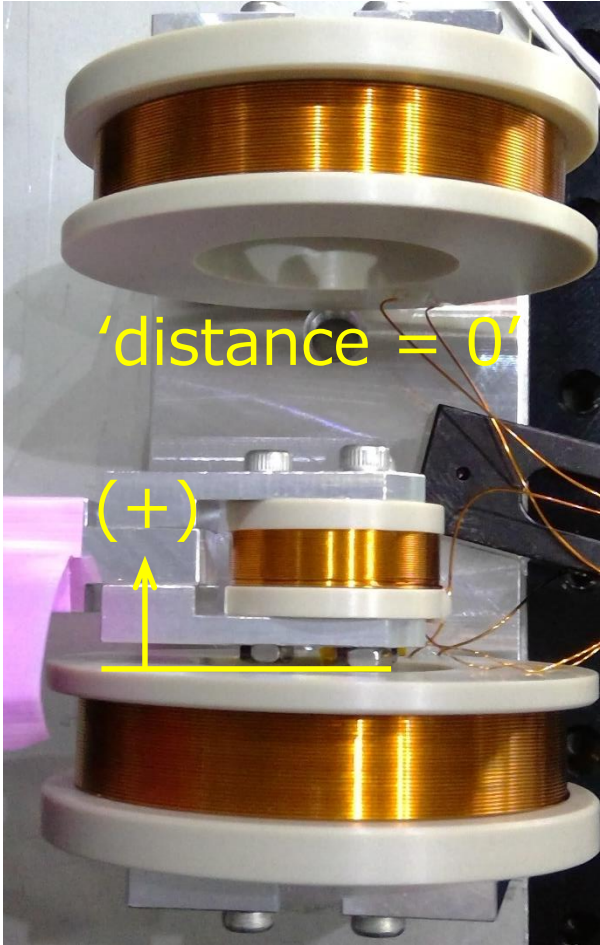

Calibration jig:

Calibration jig

Suspension parts

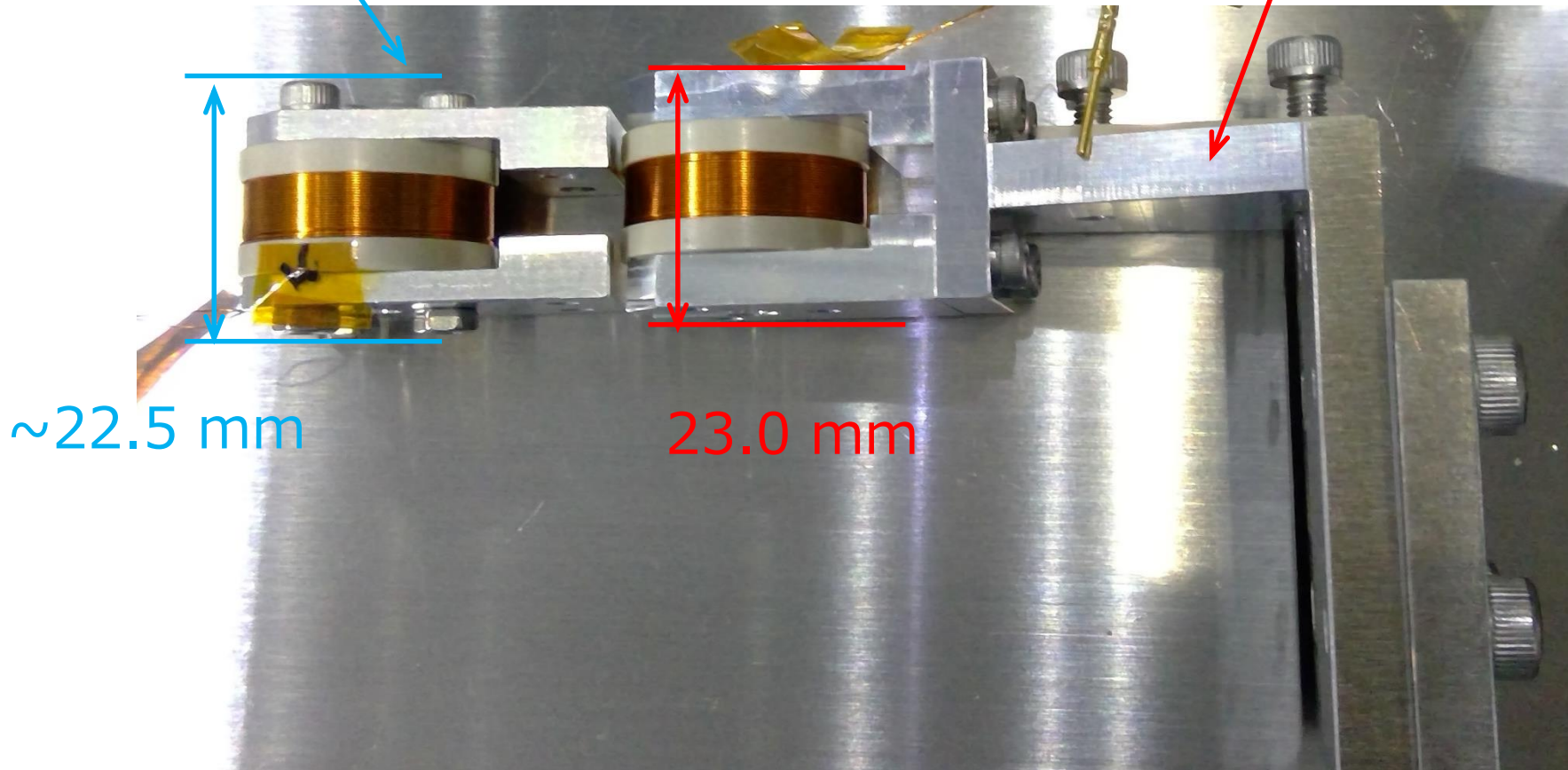

*Mostly same configuration with the actual system.

ITMX BF-LVDT: V1

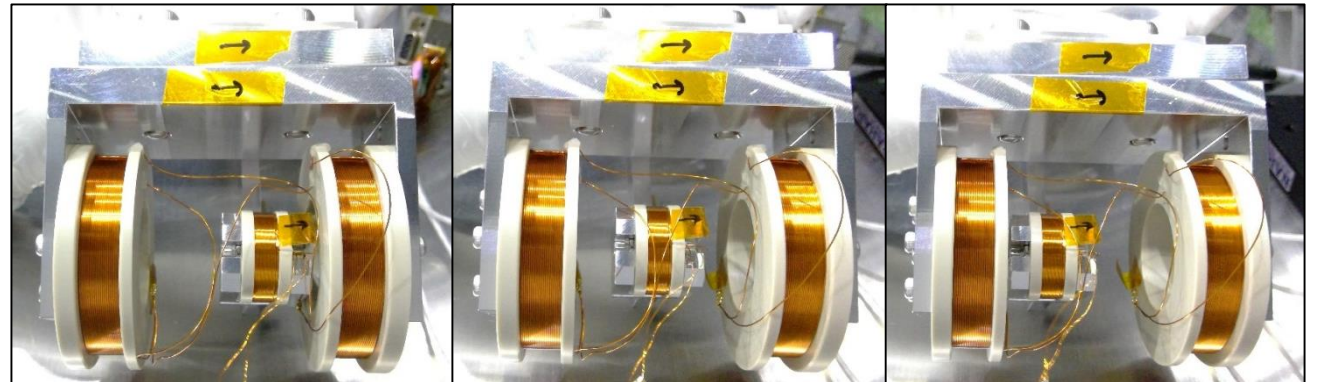
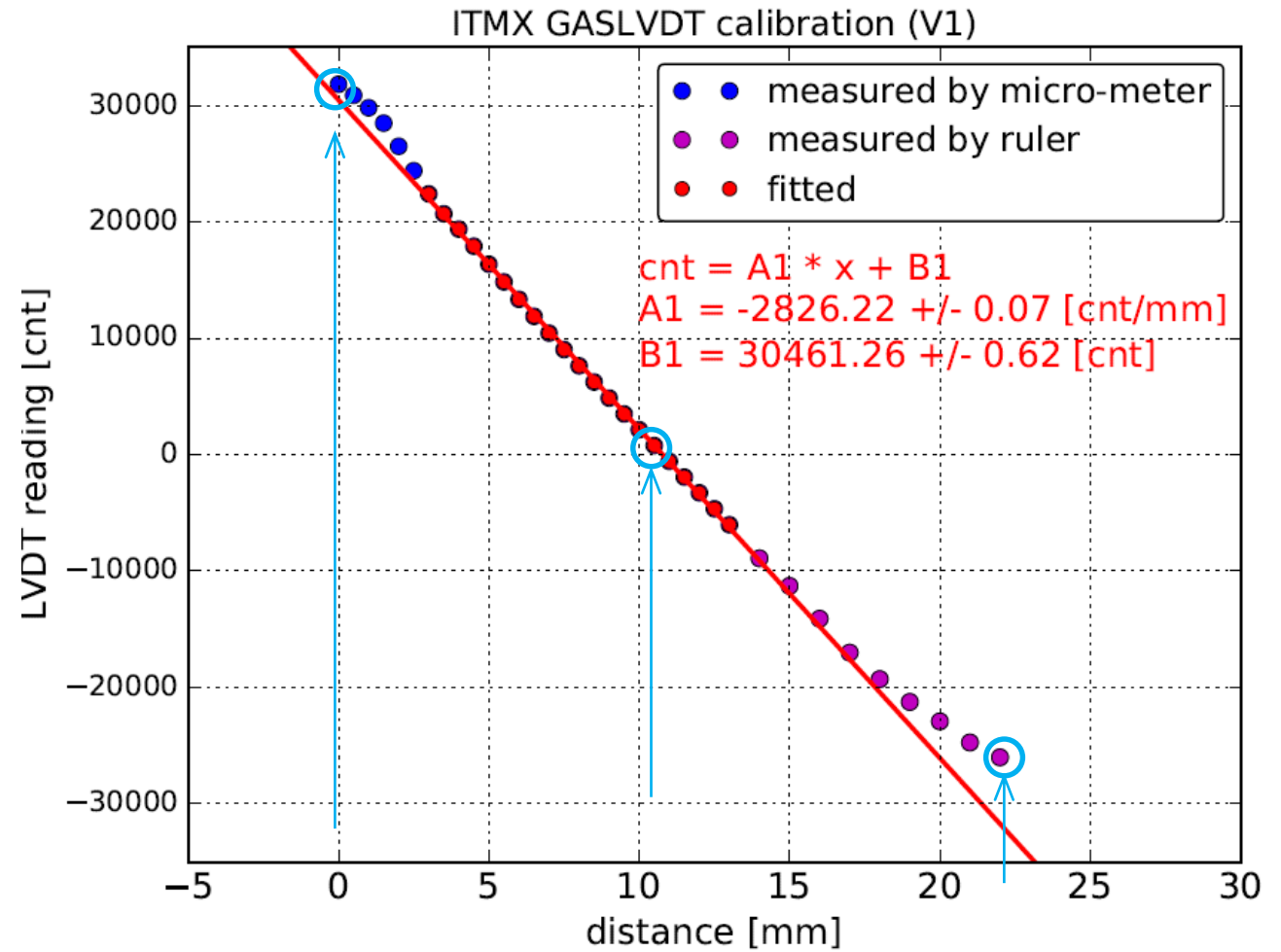

ITMX BF-LVDT: V2

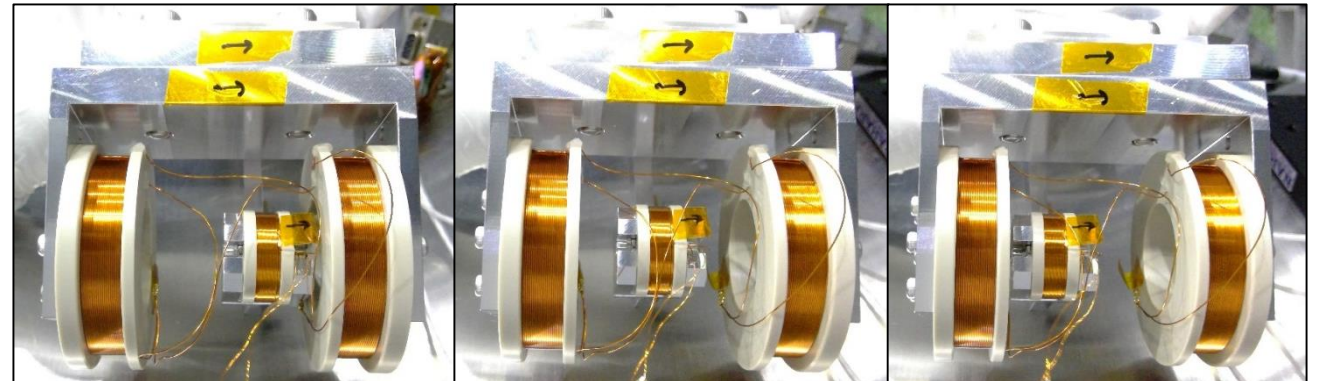
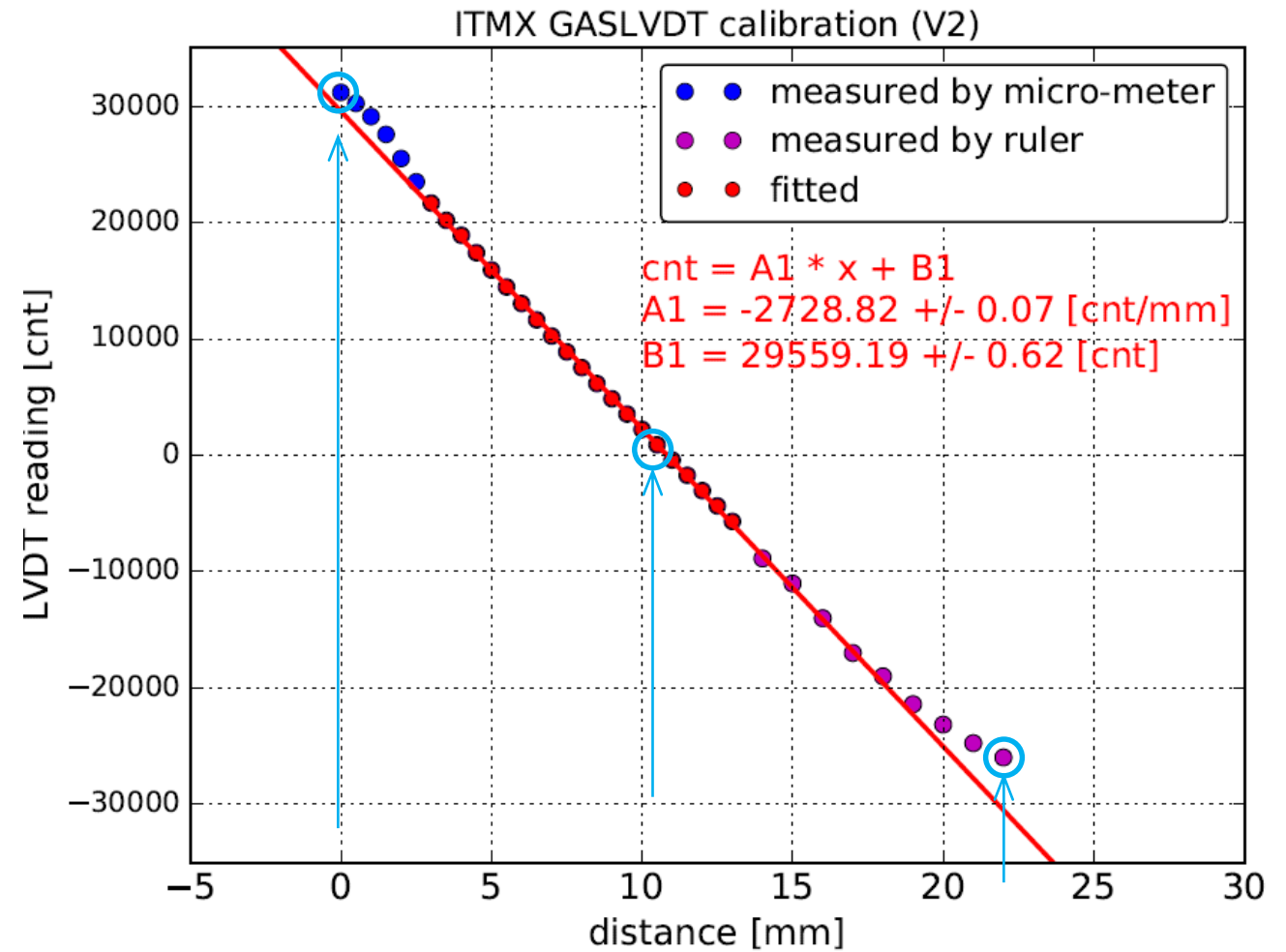

ITMX BF-LVDT: V3

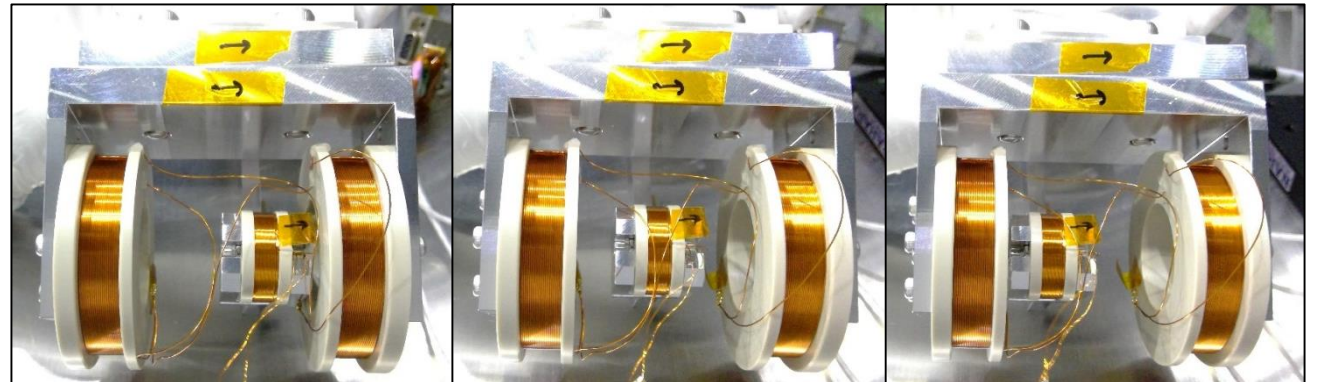
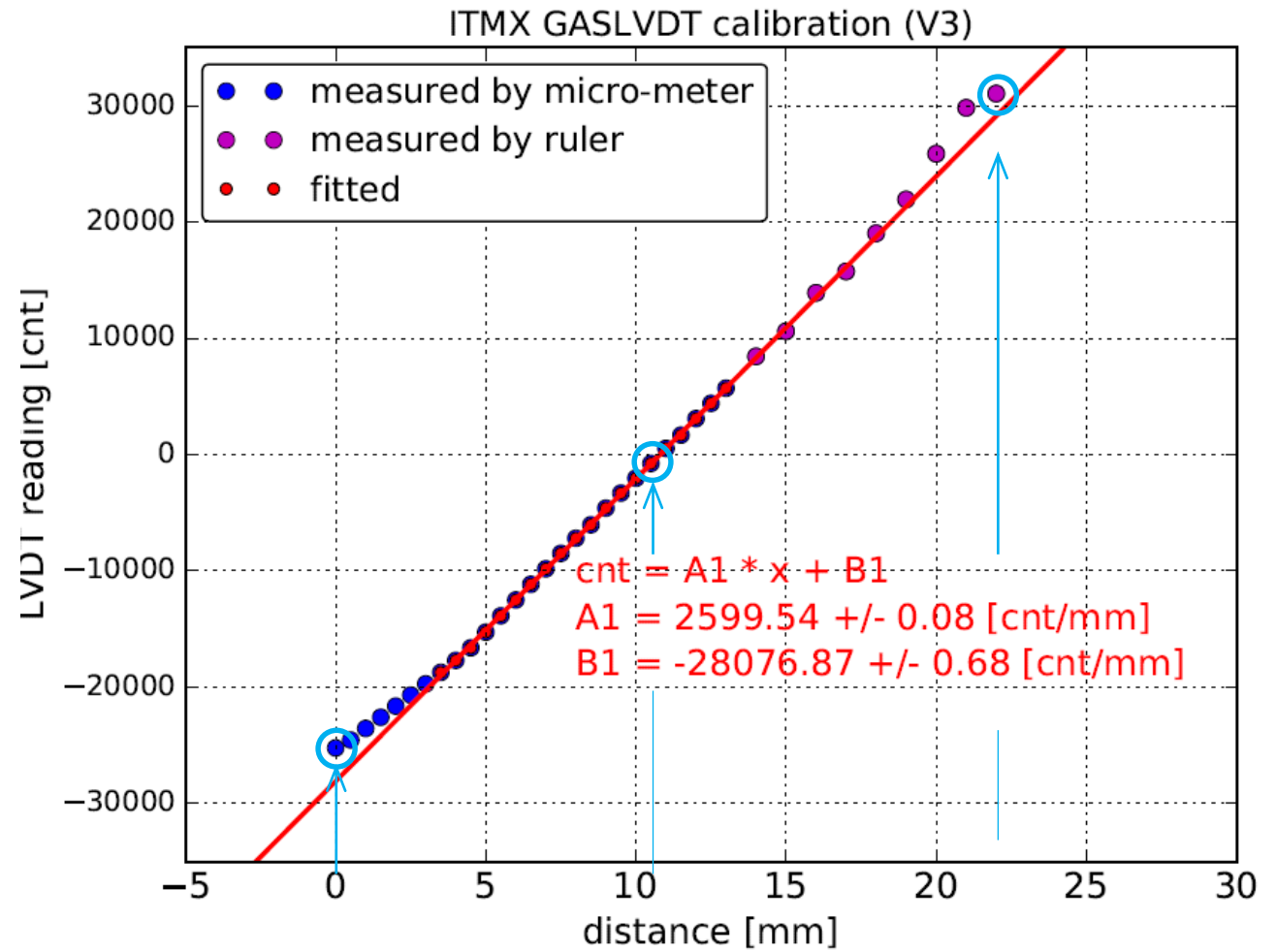

ITMX BF-LVDT: H1

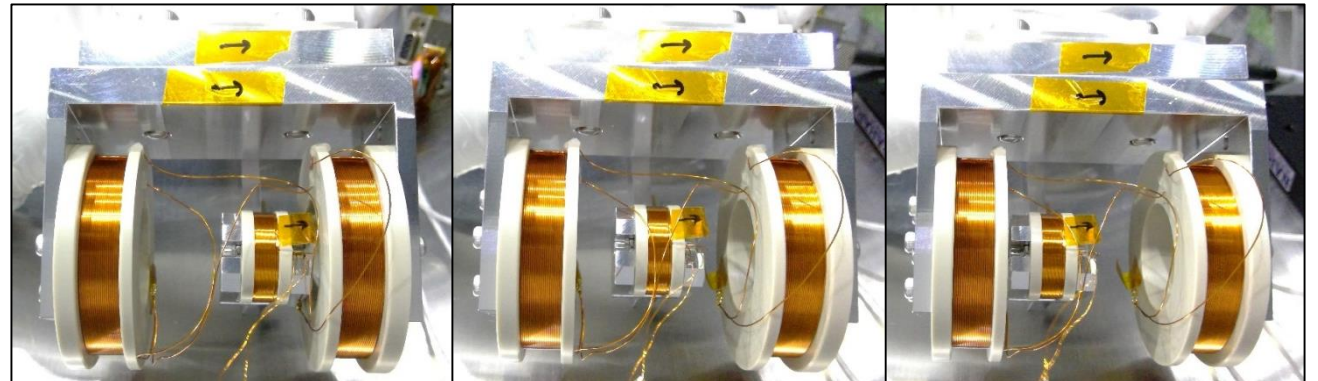
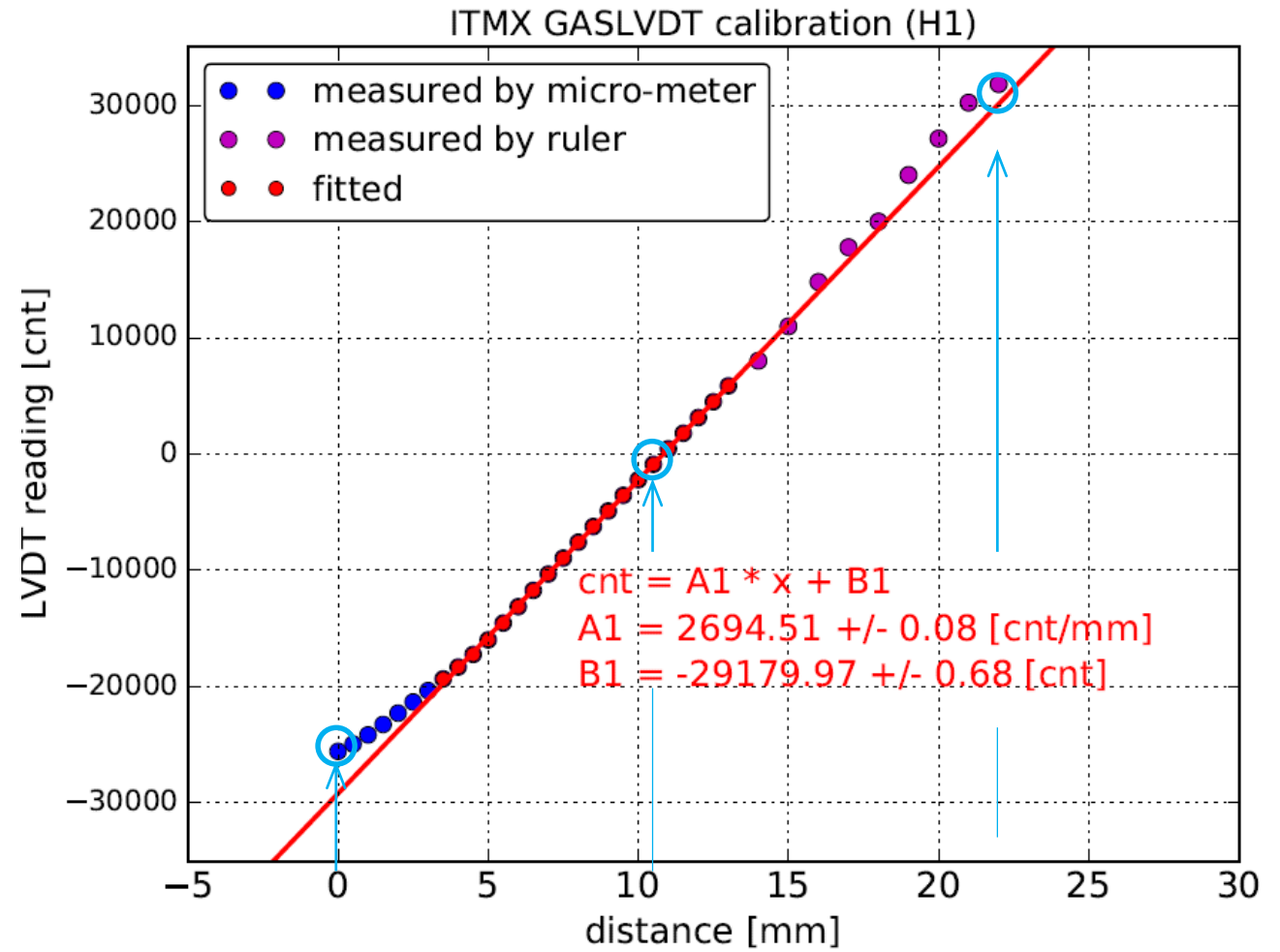

ITMX BF-LVDT: H2

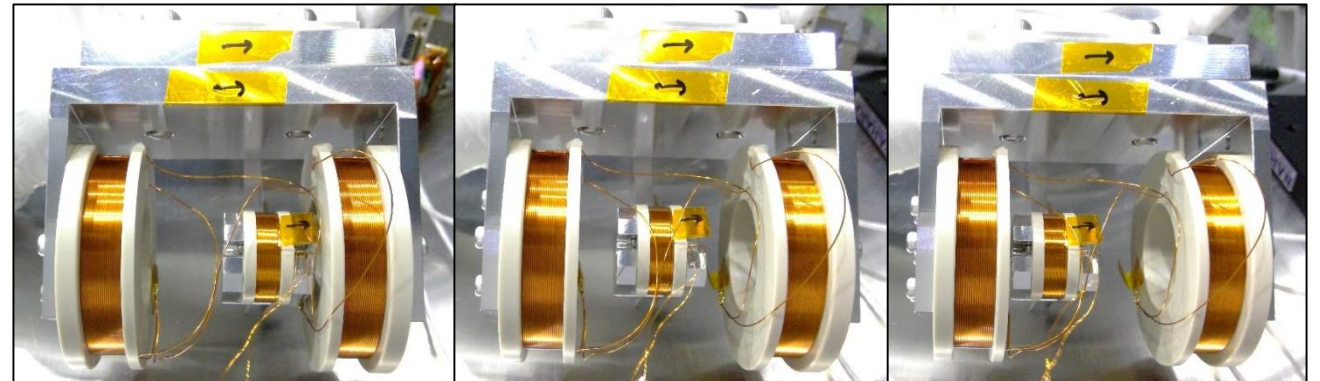
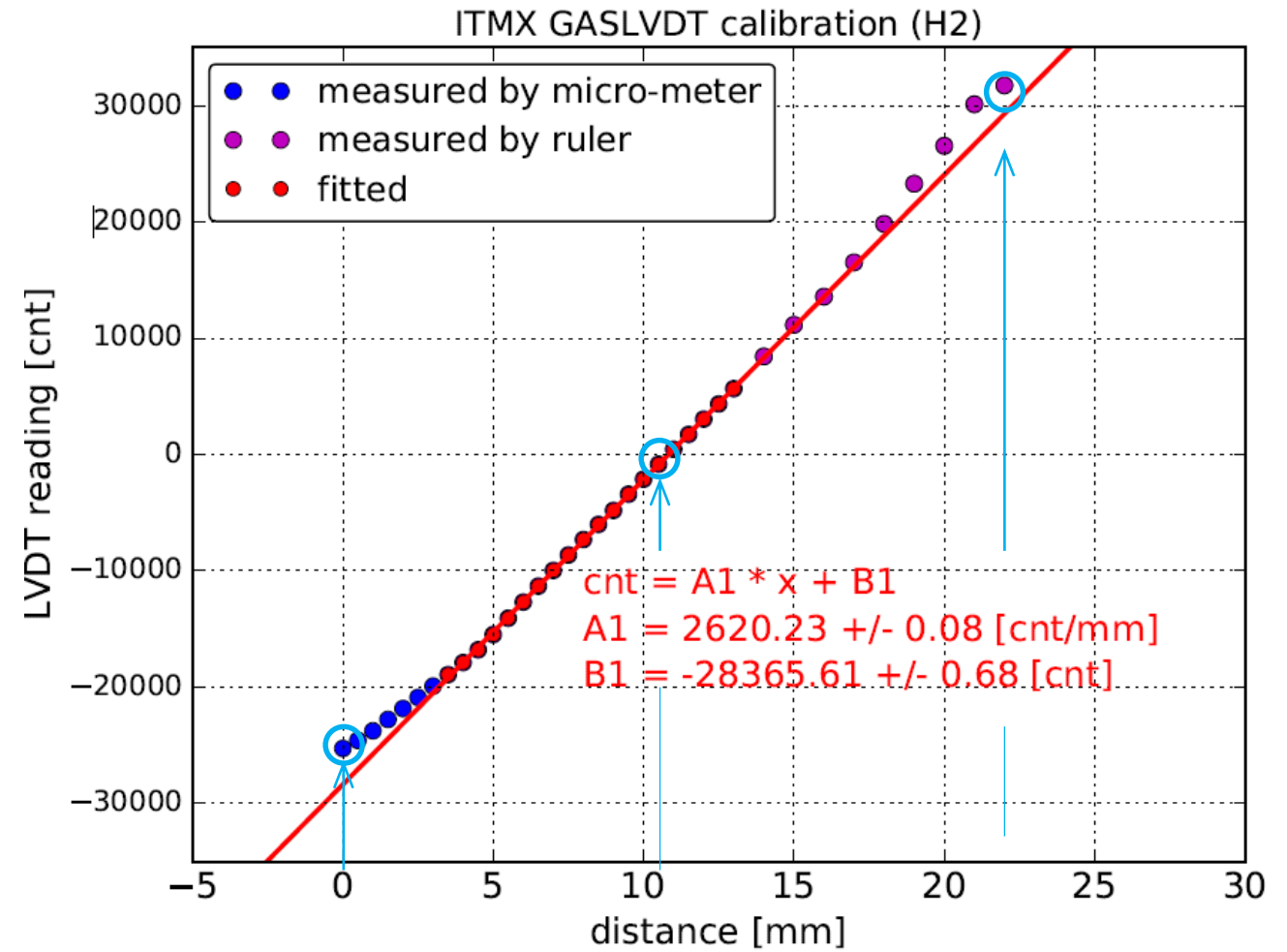

ITMX BF-LVDT: H3

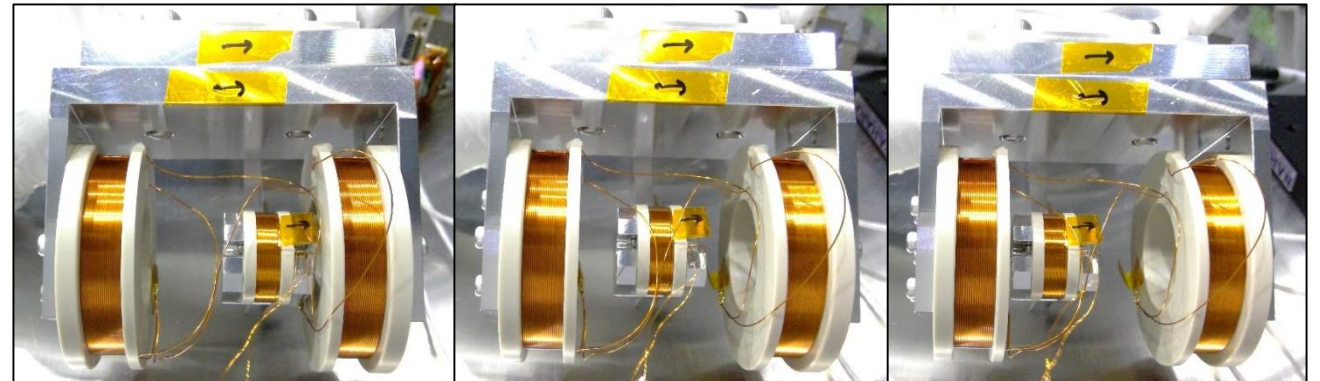
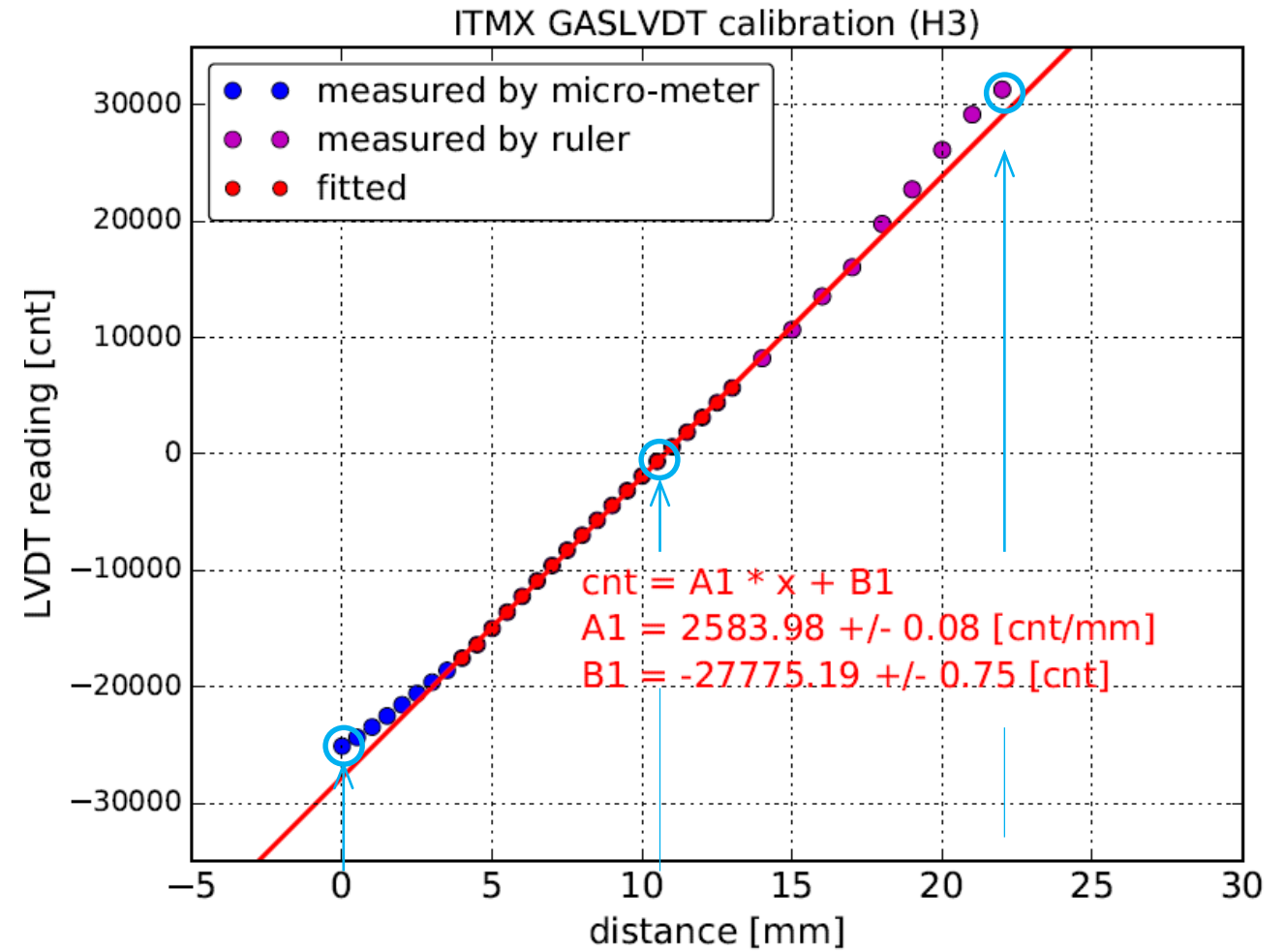

Noise level of ITMX BF-LVDT:

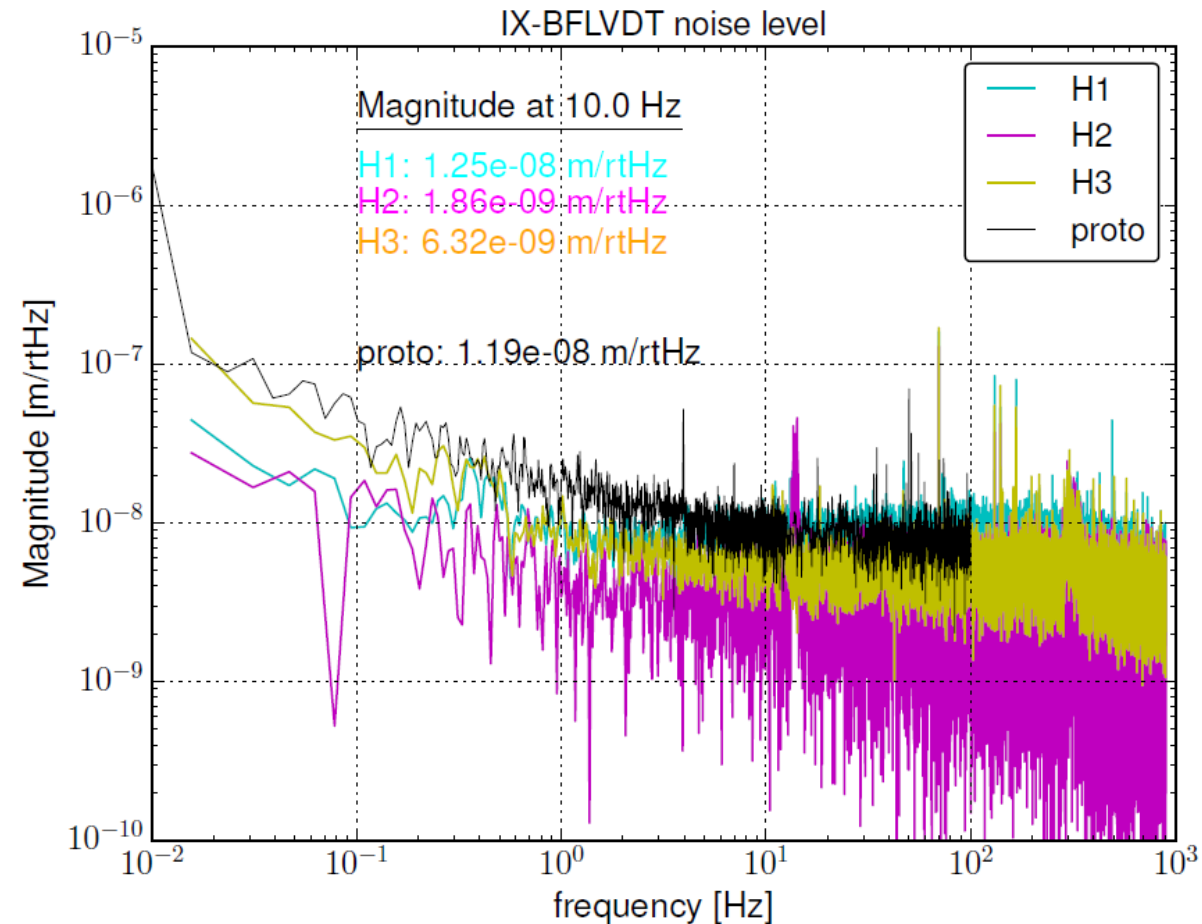
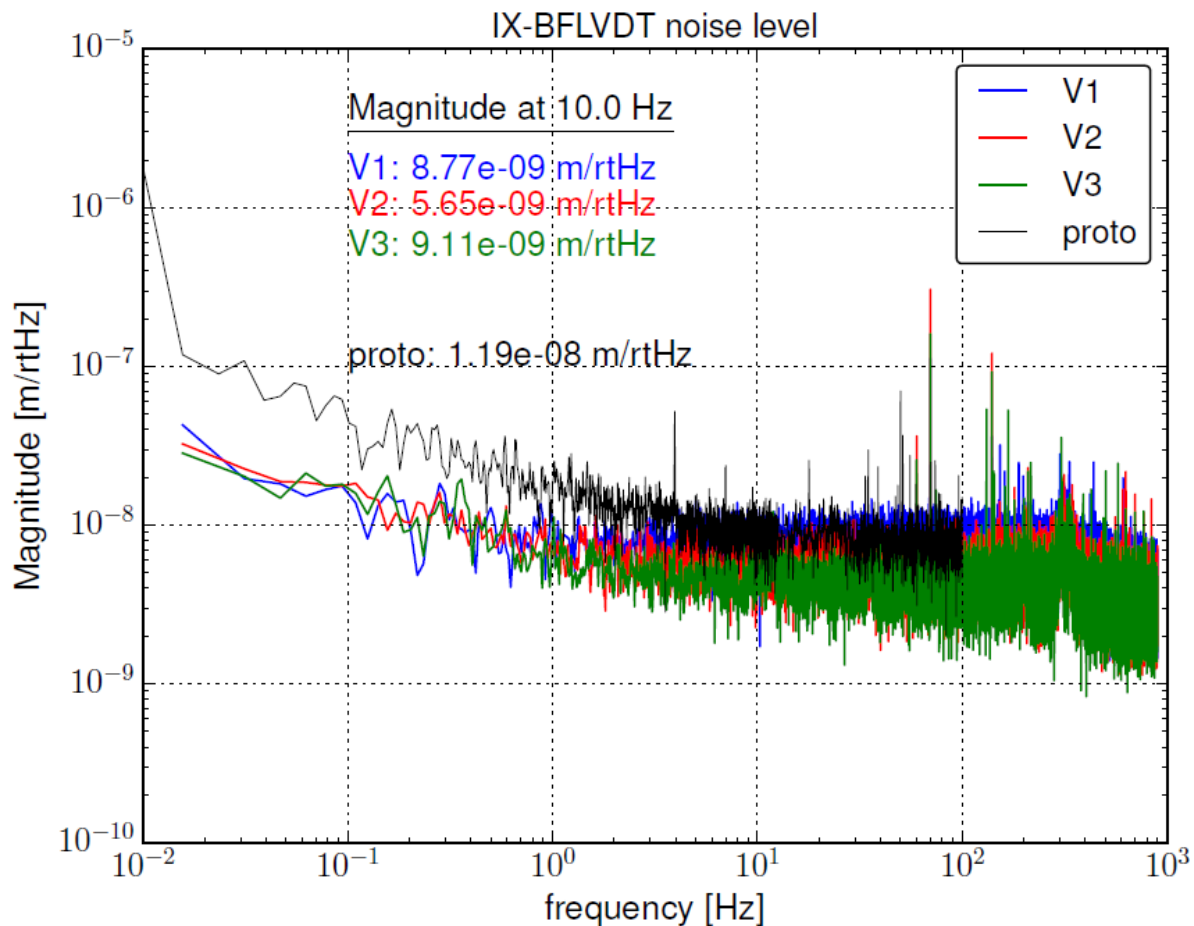

*The primary coil was locked at the center of the linear range, and then these spectra were measured.

* "proto" is from: <https://granite.phys.s.u-tokyo.ac.jp/svn/LCGT/trunk/VIS/SuspensionControlModel/noise/F7LVDTprotonoise.dat>

Noise level of ITMX BF-LVDT at some positions:

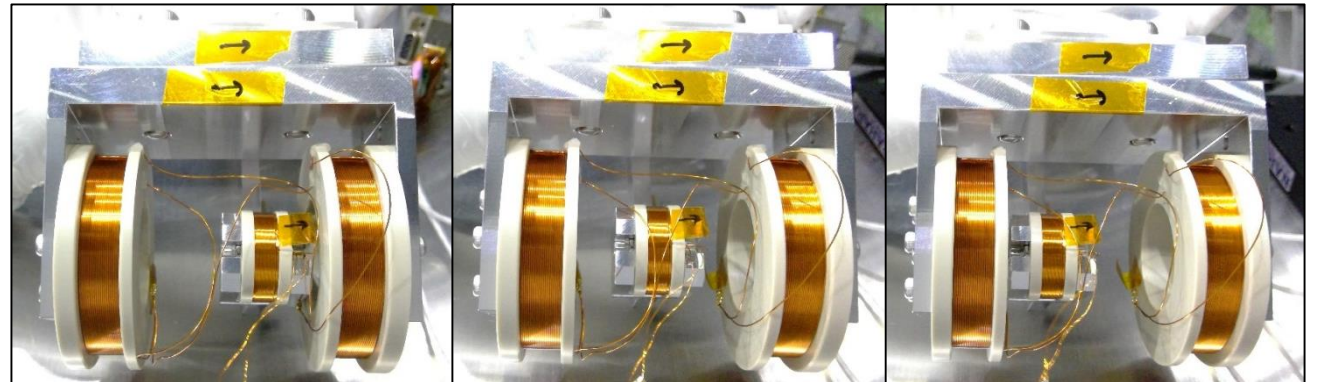
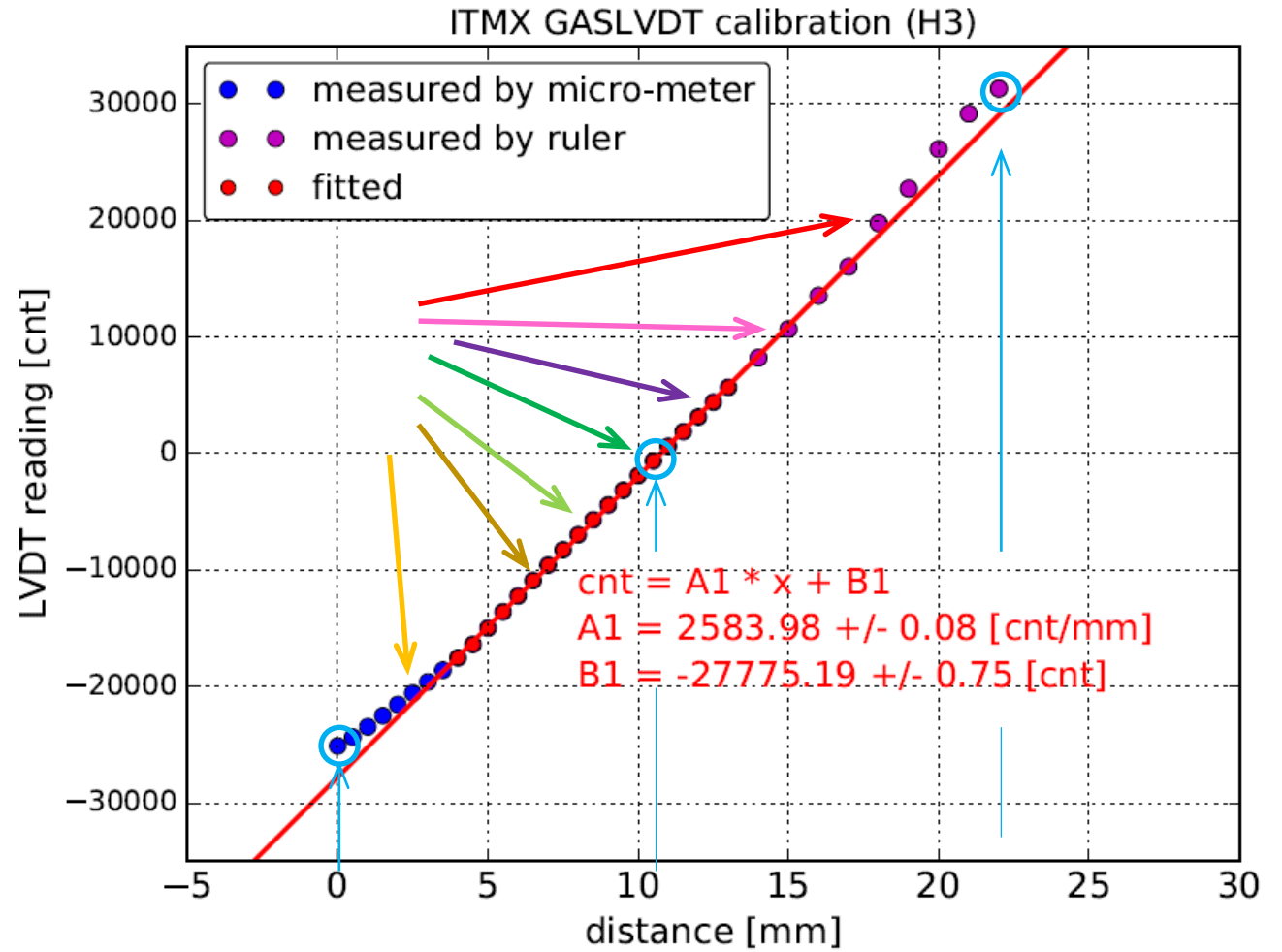

Noise level of ITMX BF-LVDT-H3: $\text{calibration factor} = 1/2583.98 \cdot 1e-3 \text{ [m/cnt]}$

Power spectrum

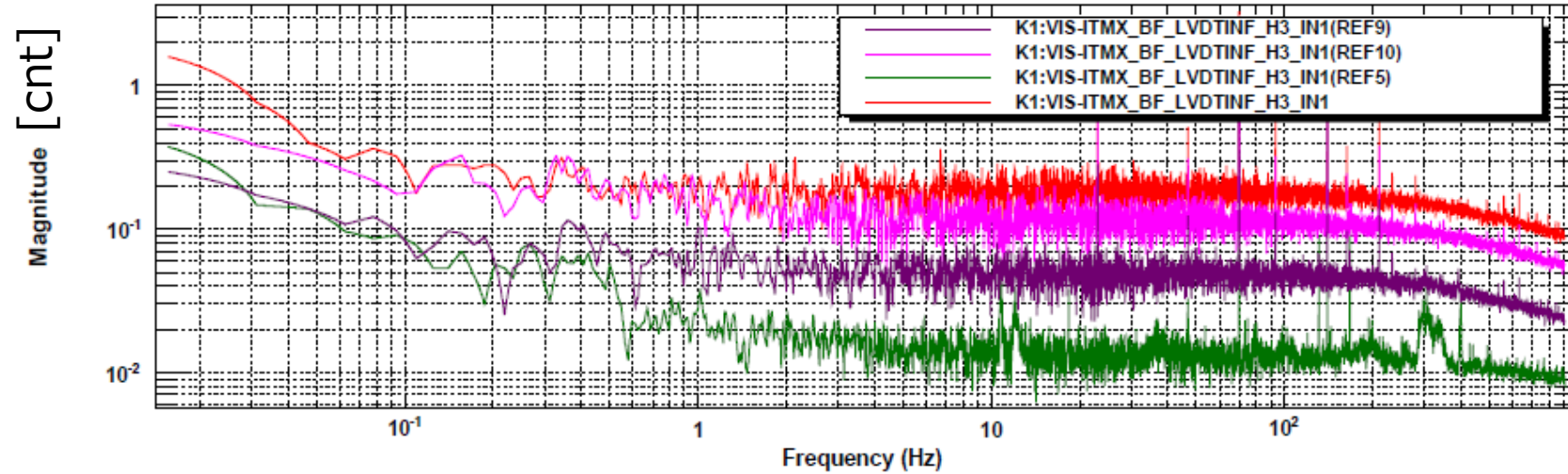

*T0=10/05/2018 05:31:06

*Avg=1/Bin=5L

BW=0.0234367

Power spectrum

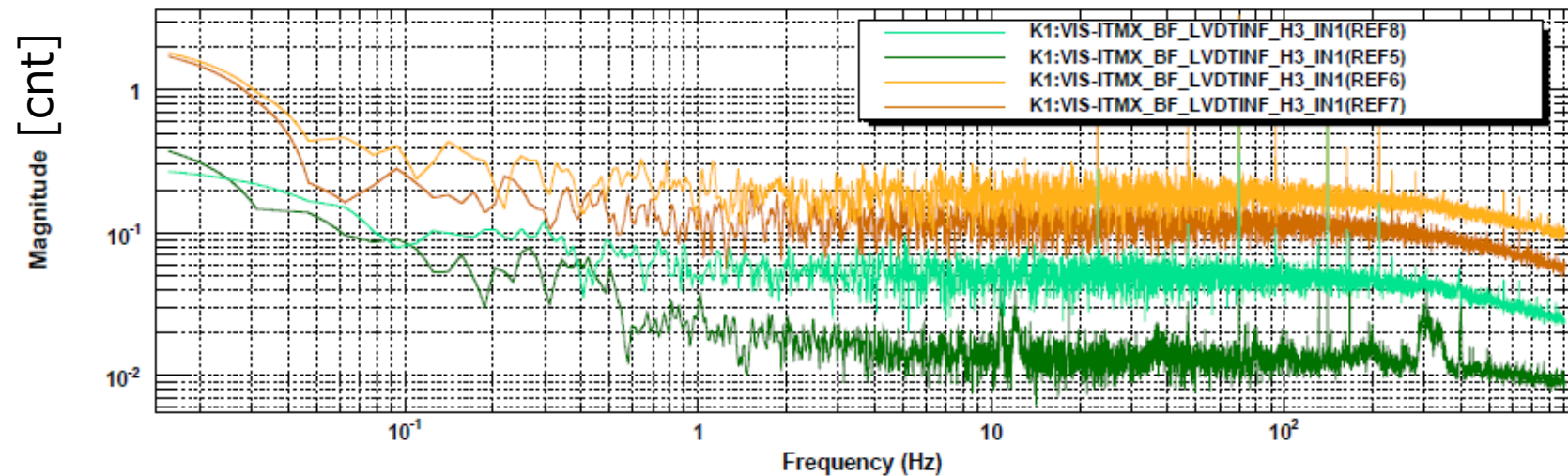

*T0=10/05/2018 05:26:18

*Avg=1/Bin=5L

BW=0.0234367

Noise level of ITMX BF-LVDT-H3:

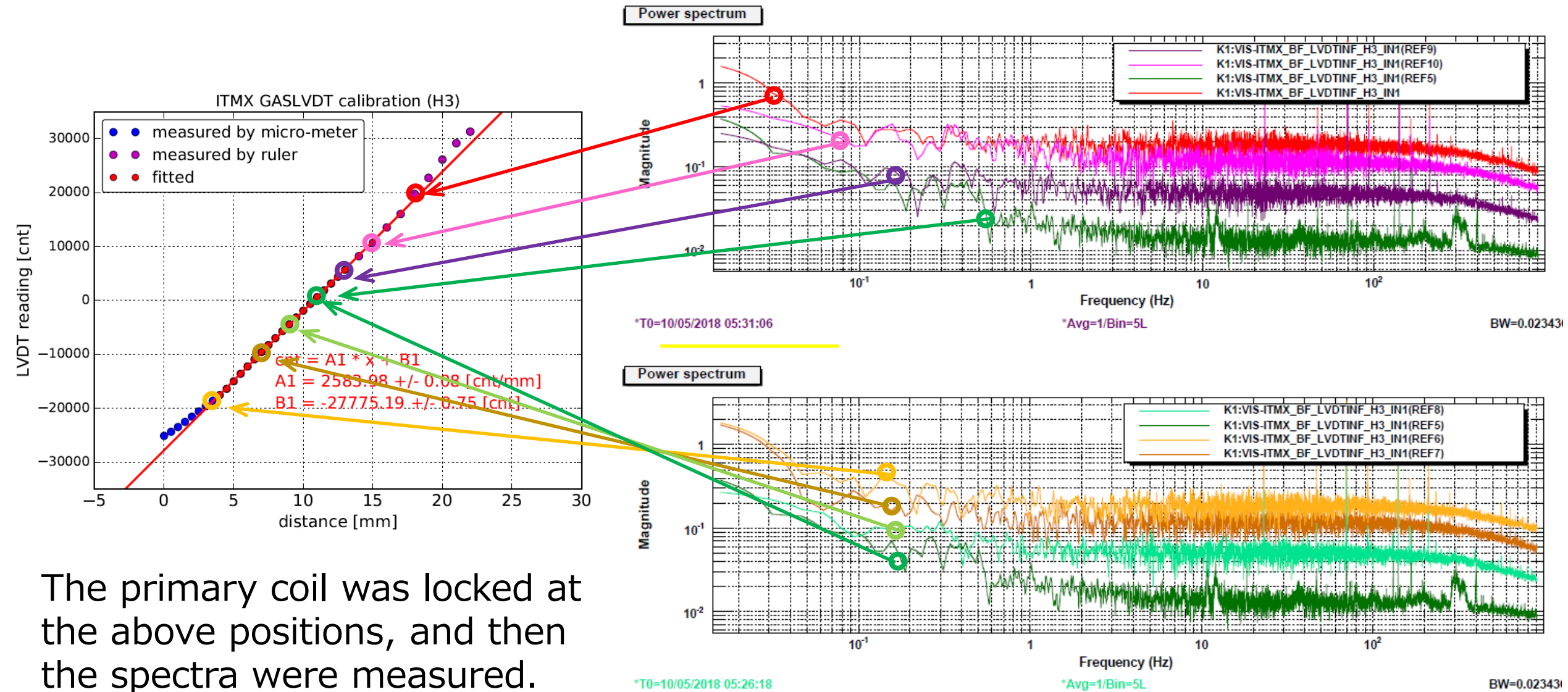

The primary coil was locked at the above positions, and then the spectra were measured.

→ Depending on the position, the noise floor changed by ~one order of magnitude.

Noise level of ITMX BF-LVDT-H3:

- We will have larger noise if we do not use BF-LVDT at the center of its linear range.
- Since the “proto” was used as BF-LVDT noise in a simulation so far (I think), we might have to update BF-LVDT noise in the simulation.

IX-BFLVDT noise level

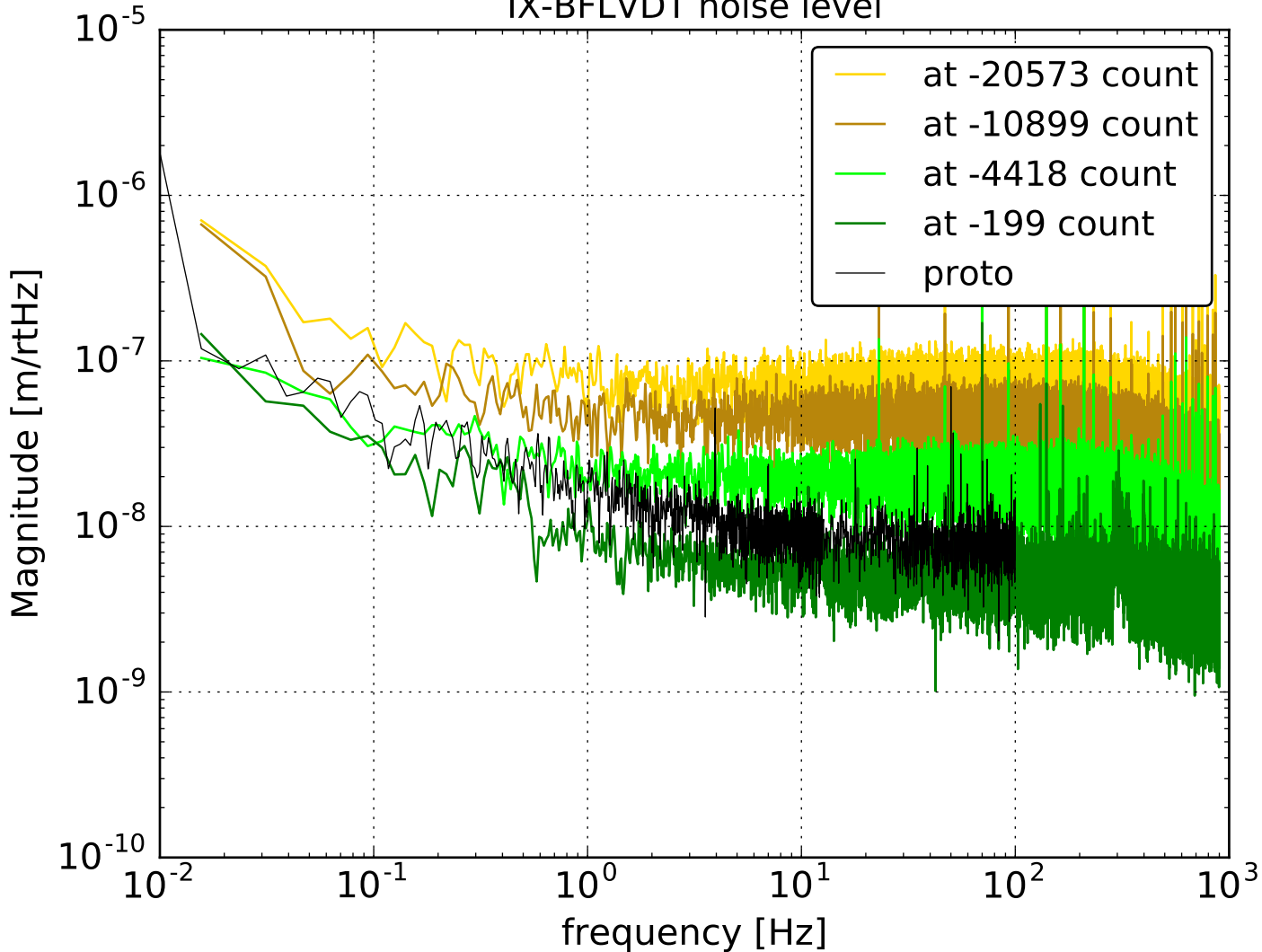

IX-BFLVDT noise level

